

Dual surface mount switching diode

BAV70W

FEATURES

- Fast switching speed.
- High conductance.
- Common cathode.
- For general purpose switching applications.
- Surface mount package ideally suited for automatic insertion.



Lead-free

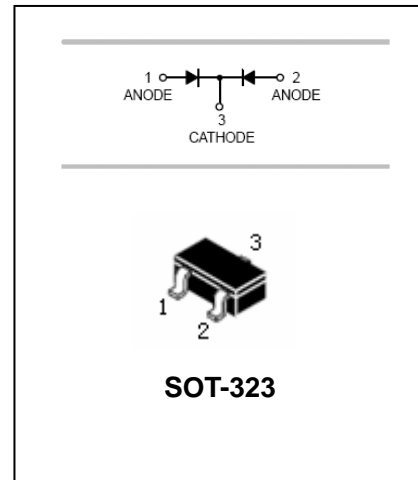

APPLICATIONS

- Small signal switching

ORDERING INFORMATION

Type No.	Marking	Package Code
BAV70W	KJA	SOT-323

MAXIMUM RATING @ Ta=25°C unless otherwise specified

Parameter	Symbol	Limits	Unit
Non-Repetitive Peak reverse voltage	V_{RM}	70	V
Diode reverse voltage	V_R	70	V
Forward continuous Current	I_F	200	mA
Forward Surge Current $t=1\mu S$	I_{FS}	4.5	A
Power Dissipation	P_d	250	mW
Junction temperature	T_j	150	°C
Storage temperature range	T_{stg}	-65 to +150	°C



Dual surface mount switching diode

BAV70W

ELECTRICAL CHARACTERISTICS @ Ta=25°C unless otherwise specified

Parameter	Symbol	Test conditions	MIN	MAX	UNIT
Reverse breakdown voltage	$V_{(BR)R}$	$I_R = 100\mu A$	70		V
Reverse voltage leakage current	I_R	$V_R = 70V$		2.5	μA
Forward voltage	V_F	$I_F = 1mA$ $I_F = 10mA$ $I_F = 50mA$ $I_F = 150mA$		715 855 1000 1250	mV
Diode capacitance	C_D	$V_R = 0V$ $f = 1MHz$		1.5	pF
Reverse recovery time	t_{rr}	$I_F = I_R = 10mA$ $I_R = 1mA$ $R_L = 100\Omega$		6	nS

TYPICAL CHARACTERISTICS @ Ta=25°C unless otherwise specified

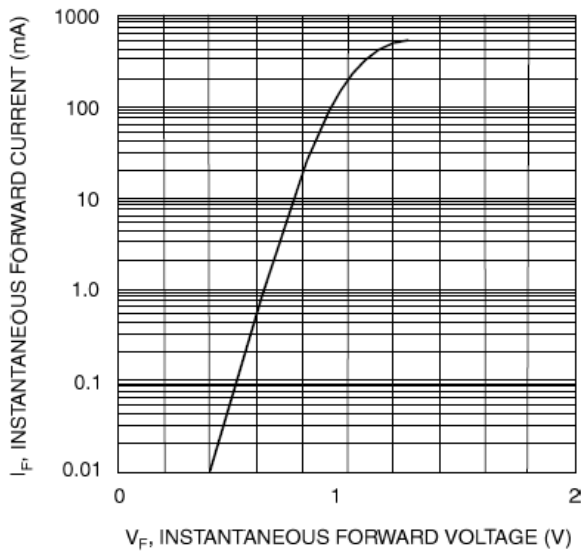

Fig. 1 Forward Characteristics

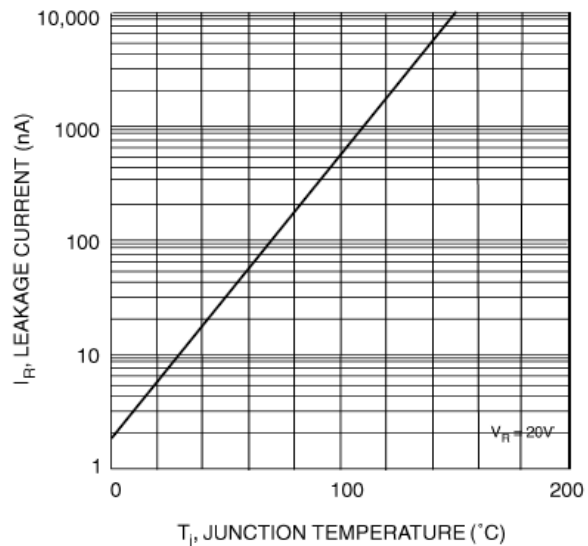

Fig. 2 Leakage Current vs Junction Temperature

Dual surface mount switching diode

BAV70W

PACKAGE OUTLINE

Plastic surface mounted package

SOT-323

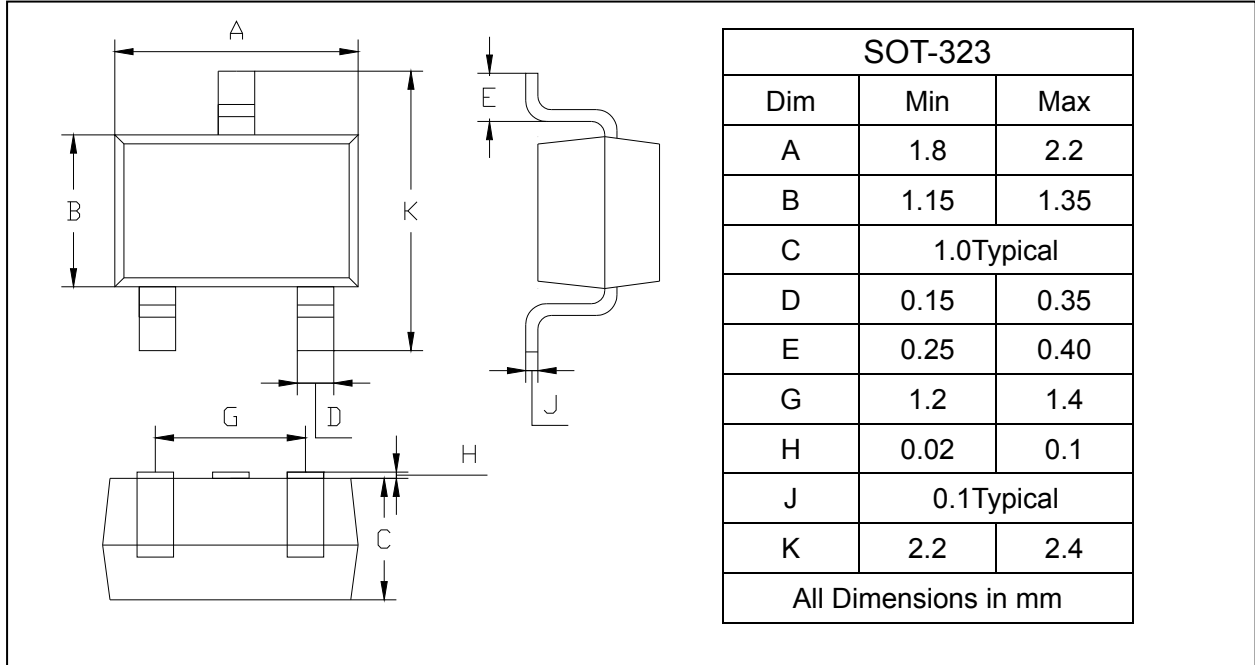

SOLDERING FOOTPRINT

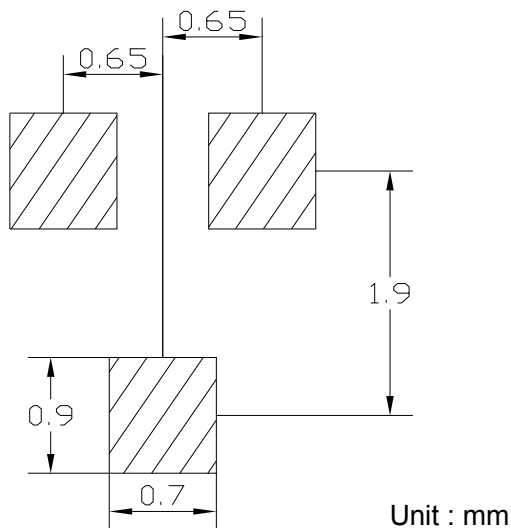

PACKAGE INFORMATION

Device	Package	Shipping
BAV70W	SOT-323	3000/Tape&Reel